

Skidmore®

A Swan Group Company

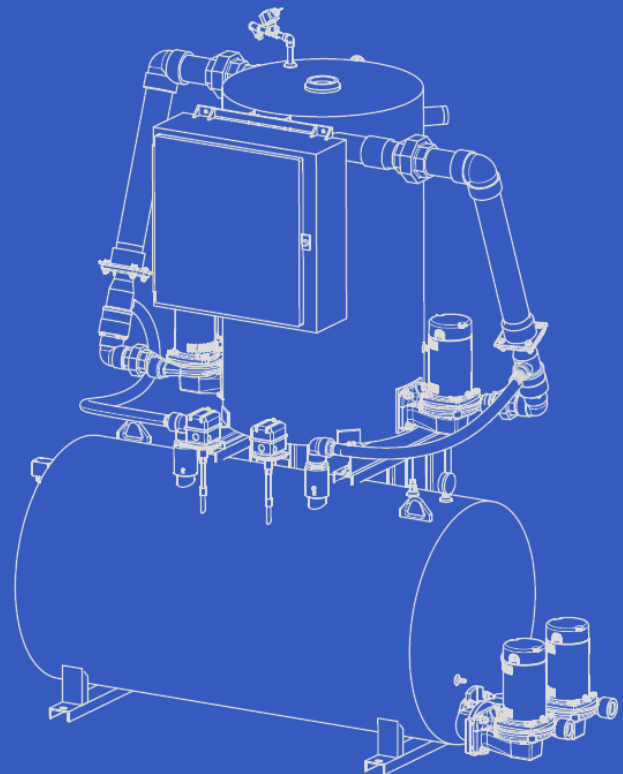
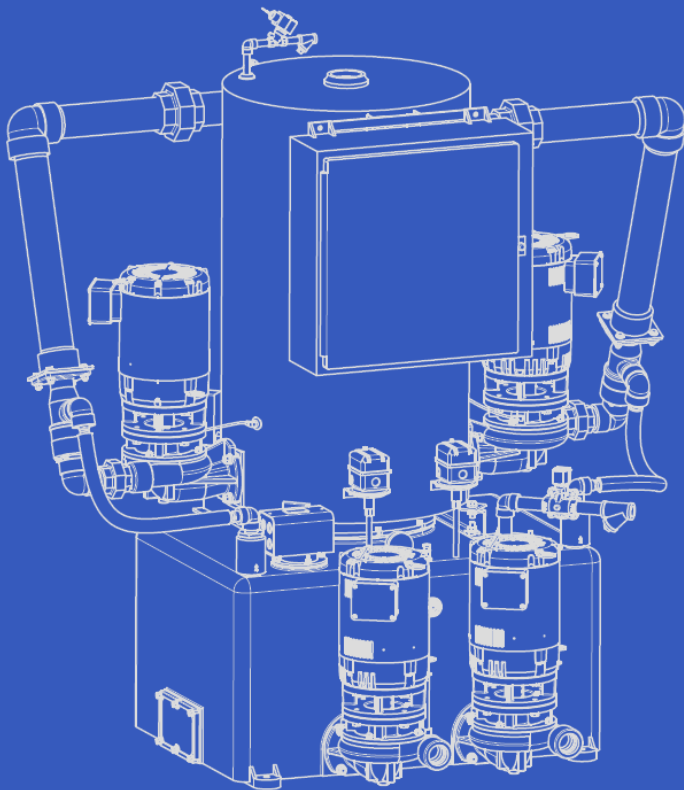

VACUUM CONDENSATE
AND BOILER FEED PUMPS

JV SERIES

JV Series Features & Specifications

- Cast Iron, Steel, and Stainless Steel Receivers.
- Capacities from 2,500 to 65,000 sf EDR.
- Air capacities from 6 to 72 CFM.
- Standard receiver capacities from 29-1000 gallons.

The Skidmore™ pumping systems described in this brochure are completely assembled, wired, and tested before shipment. They are designed to provide maximum efficiency, reliability, and easy maintenance in compact, space-saving configurations.

Each unit is factory-tested individually before shipment to ensure that the product is ready for service when received. Testing includes verification of flow rate, pressure, amperage draw, and cut-in and cut-out points of all components. You can confidently specify Skidmore products, knowing that you will receive the benefits that made the Skidmore name synonymous with quality and pride since 1921.

We invite you to compare the features and specifications of our condensate, boiler-feed, and makeup pumps with those of other units. We're sure Skidmore will be your choice.

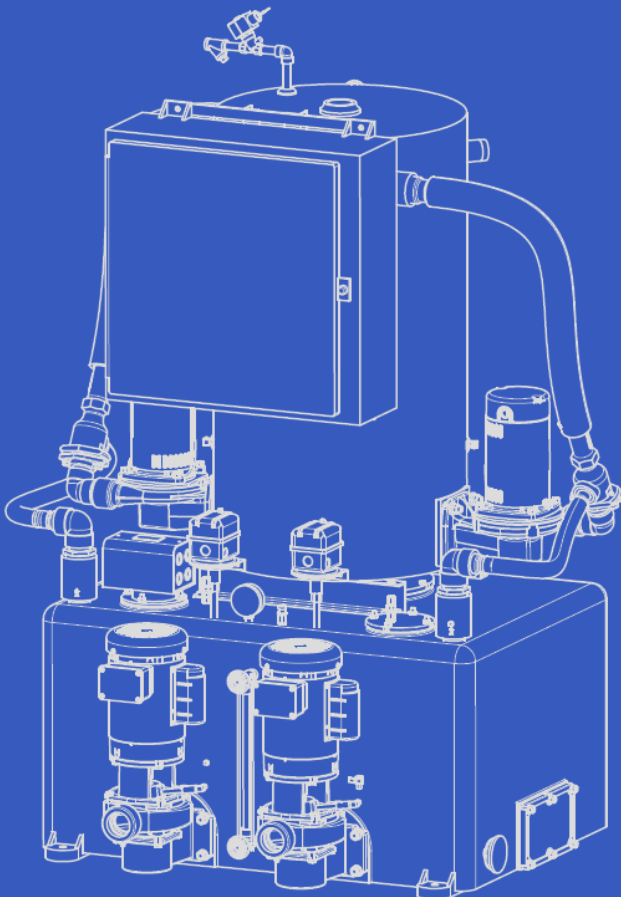

JVC and JVBF SERIES VACUUM UNITS

JVC Series units are jet vacuum condensate return type. JVBF Series units are for boiler feed and makeup water installations. The vacuum producers have air capacities from 6 to 72 CFM @ 5½" Hg, and are supplied with 3,500 rpm motors ranging from ½ to 10 hp.

JV systems offer pumping capacities anywhere from 3 to 97.5 GPM, with discharge pressures ranging from 10 to 60 PSI. For new systems, Skidmore recommends vacuum systems that have air capacities averaging 0.5 CFM per 1,000 sq. ft. EDR. This ratio of air capacity to connected load may be adjusted where desirable. An alternative ratio of 1.0 CFM per 1,000 sq. ft. EDR is recommended in the following circumstances:

- For existing buildings with old piping, where it is impractical to make the piping as tight as one a new job.
- For industrial and institutional buildings, or groups of buildings, which cover large areas with long return piping. Large air capacity provides quick and positive removal of air and condensate from all distant areas, insuring quicker warm-up, better heat and lower fuel costs.
- For zoned systems where on and off control valves are used. The fast removal of air assures more rapid and thorough distribution of steam during the "on" cycles, and, by operating the pump at a sufficiently high vacuum level, serves to counteract the induced vacuum setup during the "off" cycles. The system will be continuously drained, thus reducing spotty heating and water hammer.
- For zoned systems using modulating control. A large air capacity pump, operating at a suitable vacuum, gives better distribution of the reduced quantities of steam admitted to the system during the greater part of the heating season when the maximum quantity of steam is not required.

TYPICAL MODEL NUMBER:

JV C 28 65 VJS 2000-1.09

Product Code	Application	Vacuum CFM	Accumulator Tank Size		Condensate Pump Used
Jet Vac	C- Condensate Return	6	Rectangular	Cylindrical	
	BF- Boiler Feed	7	29 (Steel Only)	117	
		9	45	209	
		12	65	260	
		18	110	370	
		28		500	
		42		650	
		61		750	
		72		1000	

Skidmore Centrifugal Pumps

Skidmore vacuum and return pumps are centrifugal type, close-coupled bronze-fitted with drip-less mechanical shaft seals.

They are flanged directly to the receiver to provide compact, efficient design. The motor and rotating pump parts can be removed from the system without disturbing suction or discharge piping.

Return pumps are offered in pressure ranges of 10-60 psi. Sizes are available to handle 3 to 120 gpm @ 3500 rpm.

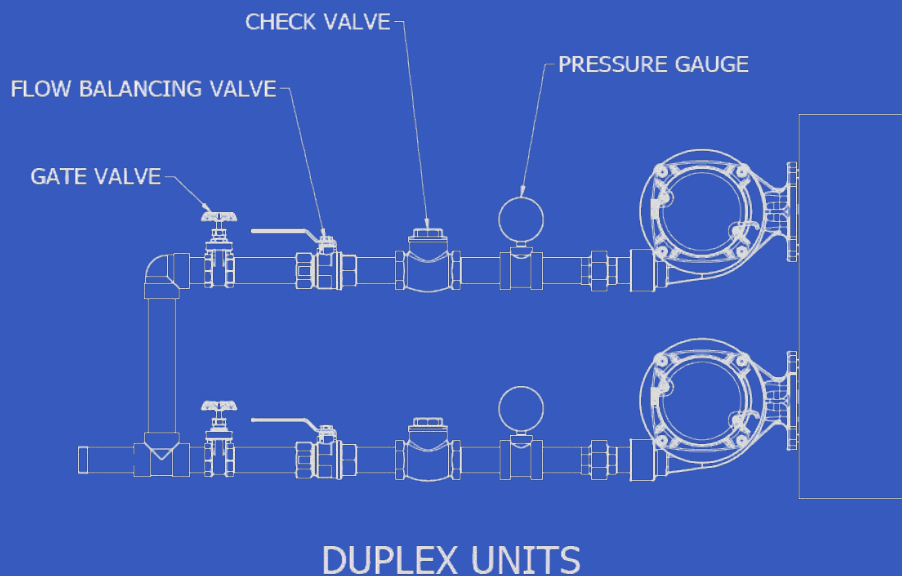

JV Series

Condensate Pumping System

Condensate pumps are used in low-pressure heating systems to collect and quickly return condensate to the boiler feed unit. The water level in the receiver controls their pumping action. Note: Condensate pumps do not supply boiler system makeup water.

Operation-Condensate Return Units (Figure 1)

1. Condensate is returned to the vacuum receiver through the RETURN inlet.
2. When the receiver water level reaches a set point, the high-level float switch starts the return pump(s), pumping water from the receiver to the boiler feed system.
3. When vacuum in the lower receiver reaches a low preset level, the vacuum switch(es) actuates the required motor controls, to turn on the vacuum pump(s) which circulates water in the seal water tank.
4. If the water in the upper water tank reaches a low preset level, a float switch-operated makeup valve is activated to replenish the water supply. A temperature-sensitive switch, wired in parallel to the makeup circuit, also permits the addition of cooling water to the water supply.

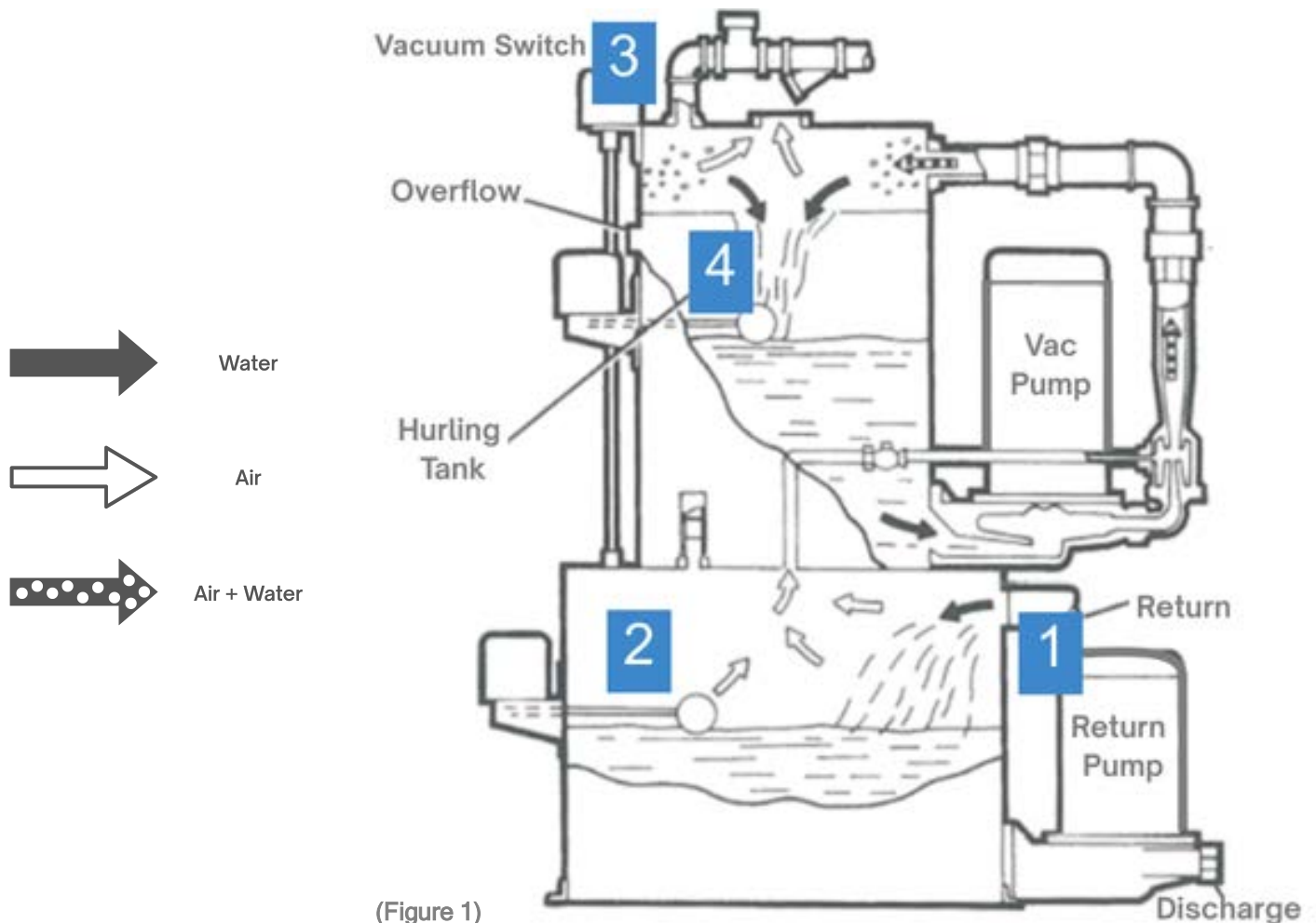

Boiler Feed Pumping Systems

Boiler Feed or Makeup Pumps

Boiler feed pumps are used to pump and precisely control the condensate and makeup water required by the boiler(s) in low pressure steam applications. Pumping action is controlled by the fluid level in the boiler.

Operation - Boiler Feed or Makeup Pumps

Condensate is returned to the vacuum receiver through return inlet.

When the water level switch in boiler(s) reaches set low level, receiver return pump is turned on, pumping water from receiver to boiler(s).

On duplex or semi-duplex units, the water level switch may control an electric alternator in motor control circuit.

When water level in receiver reaches set low level, the reverse acting float switch in receiver turns on solenoid valve, allowing water to feed from hurling tank to boiler feed receiver.

When vacuum in the lower receiver reaches a low preset level, the vacuum switch(es) actuates the required motor controls, to turn on the vacuum pump(s) which circulates water in the upper water tank.

If water in the upper water tank reaches a low preset level, a float switch operated makeup valve is activated to replenish the water supply. A temperature sensitive switch, wired in parallel to the makeup circuit, also permits the addition of cooling water into the water supply.

Receivers and Hurling/Seal Water Tanks

Cast iron, receivers are available from 45 to 110 gallon standard capacities.

Welded, heavy duty, rust resistant, copper bearing steel receivers are available in two configurations: rectangular, or cylindrical. Capacities of standard rectangular steel receivers range from 29 to 110 gallons; cylindrical versions from 49 to 1,000 gallons. Consult with your local representative for custom engineered receivers and rust resistant linings.

Upper water tanks are constructed of 3/16" thick steel - four (4) mounting brackets are drilled for 5/8" diameter bolts.

Advantages of the Vacuum Return/System

- Fast, positive air removal. Air impairs the flow of steam and acts as an insulator, preventing efficient heat emission.
- Faster return of condensate to the boiler, minimizing heat loss.
- Vacuum allows for a more unrestricted flow of steam through the system. In most cases, piping can be reduced at least one size over that required for comparable gravity return systems.
- Boilers can be operated at lower pressures, lowering operating costs.
- Better control of systems where zoned temperature is required.
- Vacuum pumps are a must for systems with long runs and central power plants. (See figure 2).

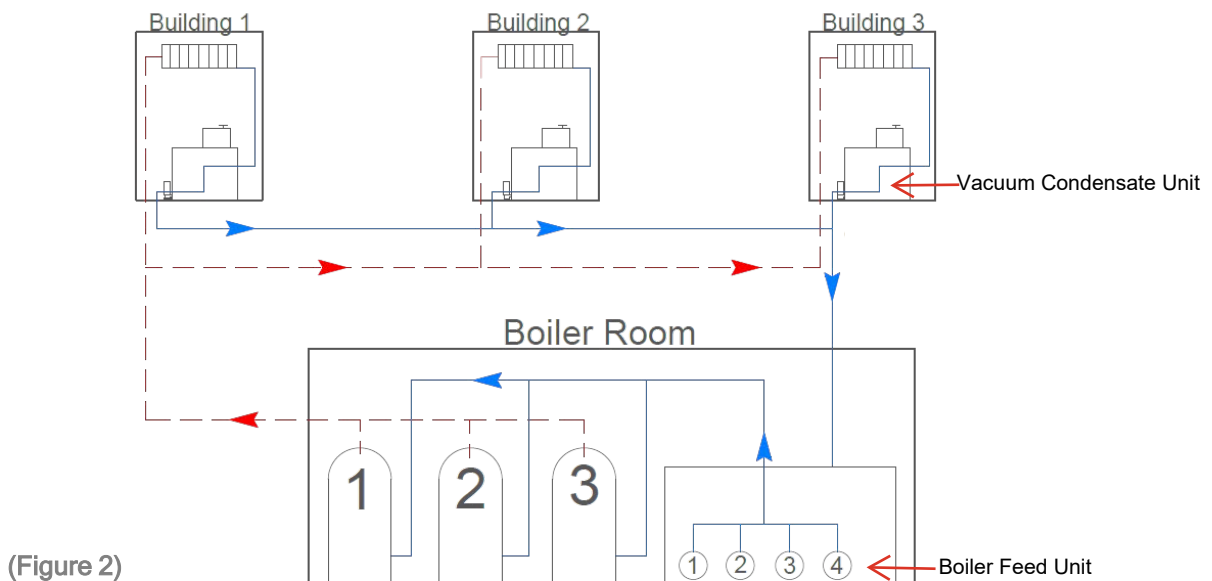

VACUUM SYSTEM STANDARD & OPTIONAL EQUIPMENT

Pumps

Close-coupled pump motors are equipped with heavy-duty ball bearings and special stainless steel shafts. Fractional-horsepower single-phase motors have built-in thermal protection. Single-phase 115/230 volt 60 Hz or three-phase 208 or 230/460 volt, 60 Hz open drip-proof motors are standard. TEFC motors are optional.

Vacuum pump motors are from 1/2 through 10 hp. Return pump motors are from 1/2 through 10 hp.

Vacuum Systems Standard Equipment

- Vacuum Relief Valve - Field adjustable, factory set below the standard operating range.
- Compound Pressure/Vacuum Gauge
- Gauge Glass - Includes shutoff valves and guard rods
- Thermometer - 40° to 220°F
- Vacuum Pump Controls - One vacuum switch (standard on simplex vacuum units)
- Two vacuum switches with an electric alternator (standard on duplex vacuum units)
- Temperature limit switch (hurling tank) - preset at 160°F. The switch is connected in parallel with the makeup valve which adds cooling water when the temperature of hurling water reaches high temperature limit.
- Venturi - with flexible hose for connection to vacuum check valve.
- Control Panel – Disconnect, Starters & Overloads, HOA Switches, Single point power connection
- Discharge Pressure Gauge(s) – 0 to 100 PSI
- Simplex systems are equipped with connections for the addition of a second pump

Condensate Return Vacuum Systems Equipment

- Return Pump Controls
 - Float switch (standard on simplex return units)
 - Mechanical alternator (standard on semi-duplex and duplex return units)

Boiler Feed Vacuum Systems Equipment

- Float switch - reverse-acting type operates the solenoid makeup valve when water reaches low level
- Makeup valve - solenoid type with inlet strainer

Optional Equipment

- TEFC motors
- Remote mount control panel with optional junction box
- Custom receiver shapes, sizes, and coatings
- Custom alarm indication (visual and audible), BMS contacts, etc

JV SERIES

Rectangular Cast Iron Receivers

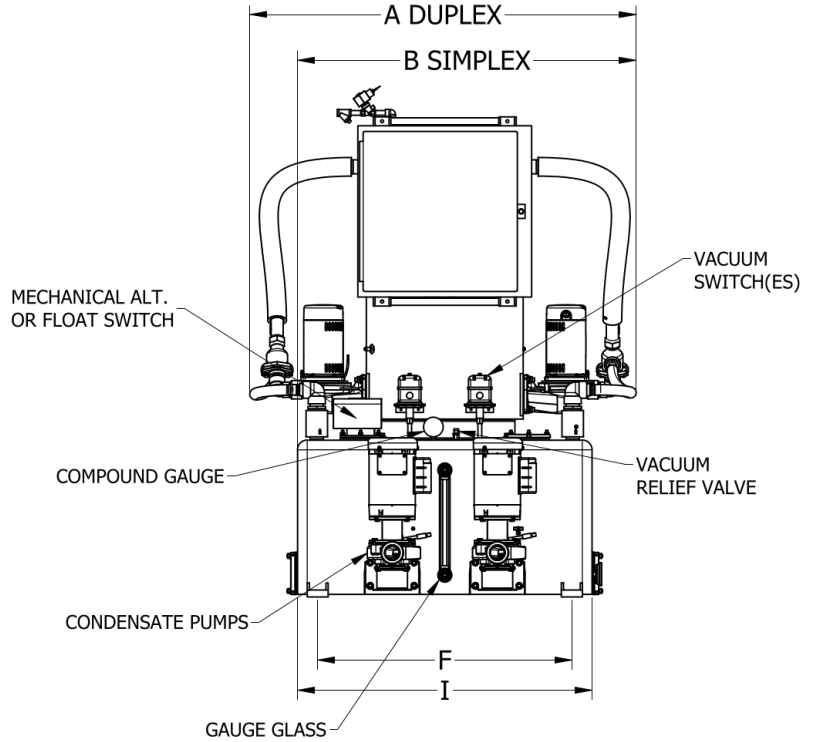
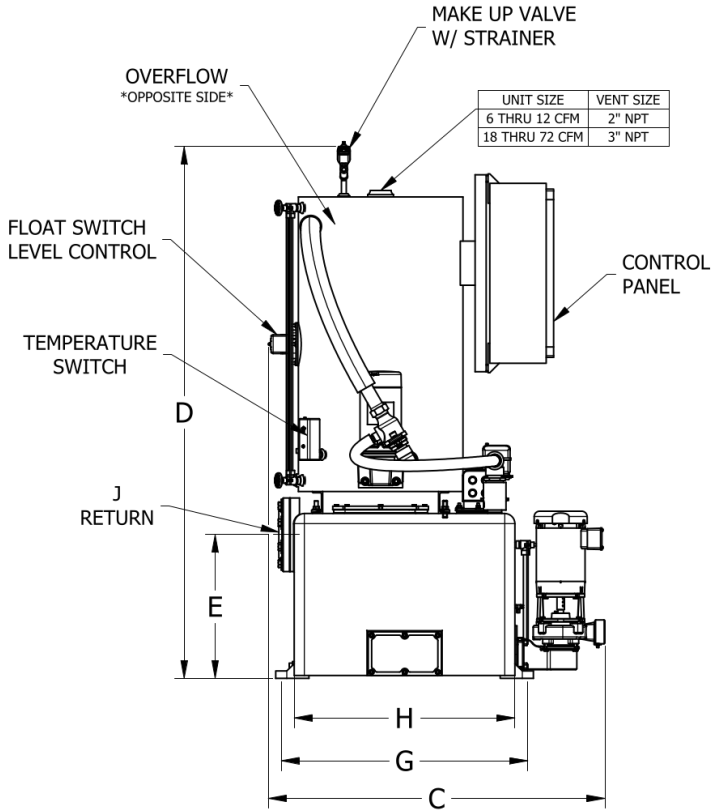

Rectangular Cast Iron Receivers

APPROXIMATE DIMENSIONS (in)

Receiver Size (Gal)	A Duplex	B Simplex	C	D			E	F	G	H	I	J NPT
				6 - 12 CFM	18 CFM	28 - 72 CFM						
45	70.7	56.4	52.8	51.3	67.3	77.8	14.5	26.8	25.8	20	28.8	2.5
65	70.7	56.4	52	55.9	71.9	76.7	19	28.5	28.3	22.8	30.5	3
110	70.7	56.4	52.4	56.4	72.4	77.8	19.5	36.3	32	30	42	4

ALL DIMENSIONS ARE APPROXIMATE

JV SERIES

Rectangular Steel Receivers

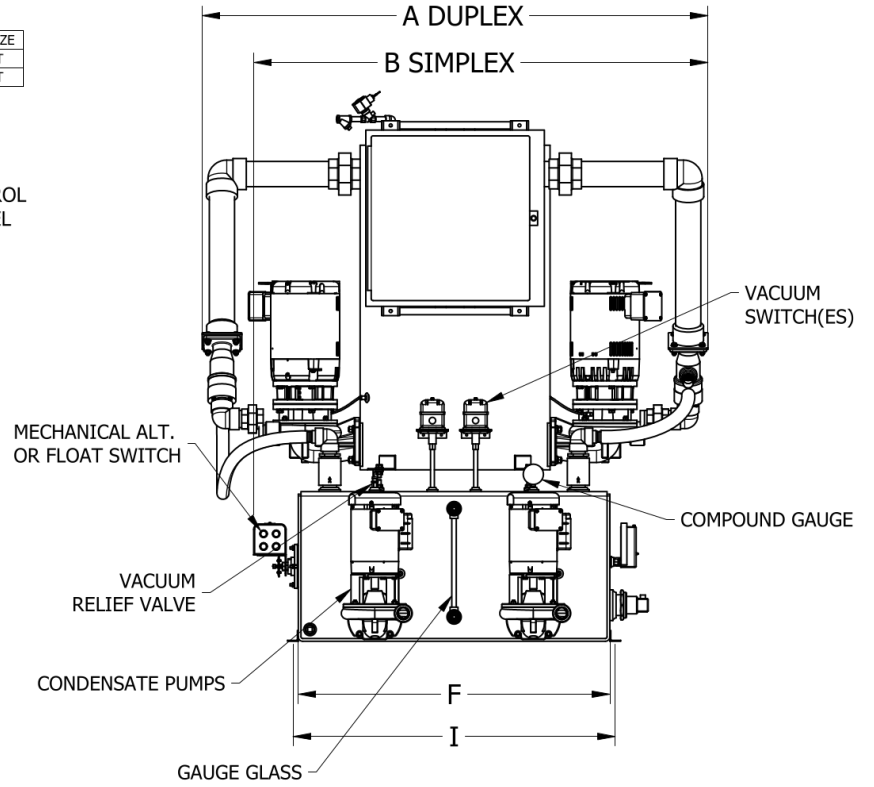
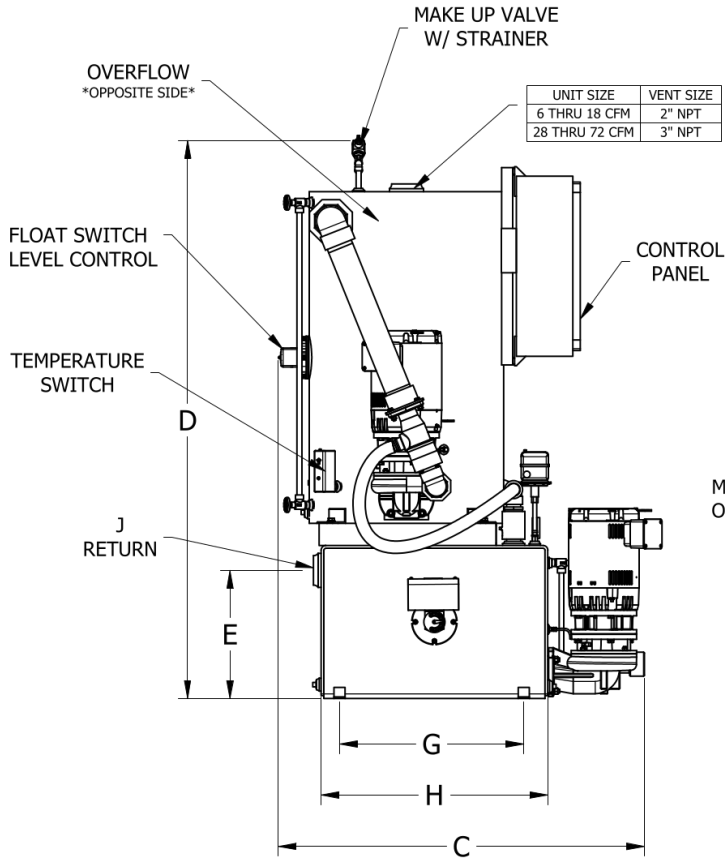

Rectangular Steel Receivers

APPROXIMATE DIMENSIONS (in)

Receiver Size (Gal)	A Duplex	B Simplex	C	D			E	F	G	H	I	J NPT
				6 - 12 CFM	18 CFM	28 - 72 CFM						
29	70.5	45.7	40.5	46.8	62.8	67.7	10.4	26.8	22.5	24.8	24.8	2
45	70.5	47.5	44.4	52.8	68.8	73.7	15.9	26.8	22.5	24.8	24.8	2
65	70.5	47.5	44.4	28.8	74.8	79.7	21.9	26.8	22.5	24.8	24.8	2
110	70.5	56.9	49.7	54.8	70.8	75.7	17.4	45.3	25	30.8	43.3	3

ALL DIMENSIONS ARE APPROXIMATE

DIMENSION DATA

JV SERIES

Cylindrical Steel Receivers

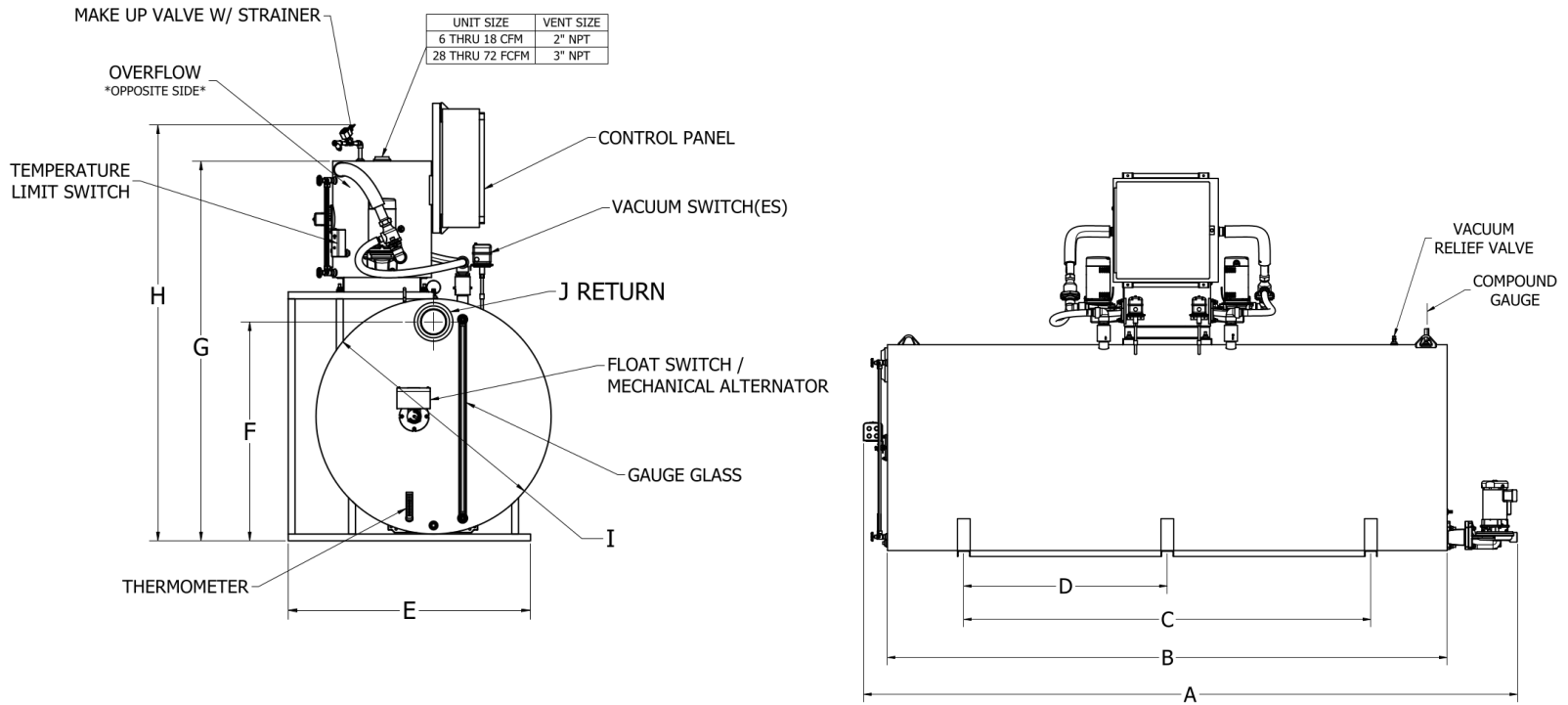

Cylindrical Steel Receivers

APPROXIMATE DIMENSIONS (in)

Receiver Size (Gal)	A	B	C	D	E	F	G			H	I	J NPT
							(6 - 12 CFM)	(18 CFM)	(28 - 72 CFM)			
117	75.8	60	30	-	34.3	22.6	54.3	70.9	75.9	G + 7	24	5
209	75.8	60	48	-	34.3	29	62	78.5	83.5	G + 7	32	5
260	75.8	60	48	-	36.3	33.2	66.3	82.3	87.3	G + 7	36	5
370	99.8	84	56	-	36.3	33.2	66.3	82.3	87.3	G + 7	36	5
500	99.8	84	56	-	39	39.2	72.3	88.3	93.3	G + 7	42	5
650	123.8	108	56	28	39	39.2	72.3	88.3	93.3	G + 7	42	5
750	111.8	96	56	28	50	45.2	78.3	94.3	99.3	G + 7	48	5
1000	148.5	132	96	48	50	45.2	78.3	94.3	99.3	G + 7	48	5

*650 GALLON AND LARGER SUPPLIED WITH CENTER SUPPORT SADDLE

ALL DIMENSIONS ARE APPROXIMATE

TYPICAL ENGINEERING SPECIFICATIONS

- 1.1 Furnish and install the quantity of jet vacuum units shown on the drawing according to the plans and manufacturer's instructions. The unit shall be of the type in which returning condensate and air are separated in the receiver tank under vacuum. Condensate is removed from the accumulator tank either by rising liquid or a boiler call. Air and vapor are removed from the system via vacuum switches.
- 1.2 Each unit shall consist of two tanks, a condensate receiver, and a vacuum producer assembly. The condensate receiver shall include the following equipment: a basket-type inlet strainer, gauge glass, compound gauge, thermometer, vacuum relief valve, suction check valves, and a mechanical alternator on units with two condensate pumps, and a single float switch on simplex units. As well as a duplex vacuum producer including a steel hurling tank, two vacuum/air pumps, gauge glass, hurling water level float switch, make-up solenoid valve with inlet strainer, temperature limit switch, electric alternator, & vacuum switches.
- 1.3 Vacuum producers' make-up water is to be through a tank-mounted 3/8" solenoid valve with an inlet strainer, controlled by a reverse-acting float switch and a temperature-limiting switch, both preset from the factory. Gauge glass shall contain shut-off cocks. Overflow connection shall be piped to the nearest available floor drain. The condensate receiver shall be manufactured of rust-resistant steel, stainless steel, or cast iron and shall have a capacity of no less than that shown on the drawings.
- 1.4 The air and condensate pumps shall be centrifugal, permanently aligned, and driven by vertical close-coupled drip-proof motors. The motors and rotating parts shall be removable without disturbing suction or discharge piping. Pumps shall be bronze, fitted with enclosed bronze centrifugal impellers, stainless steel shafts, dripless mechanical seals rated for 250°F, and a mechanical seal flushing line with a vent to volute.
- 1.5 Each unit shall contain a factory-provided and wired NEMA 2, UL-certified electrical control panel with one main disconnect with cover interlock, magnetic starters and overloads for each pump, fuse blocks, HOA selector switches, control circuit transformer, and a terminal block and grounding lug.

EDR	Air Flow Required (CFM)	Pump Capacity (GPM)	Pump Discharge Pressure (PSI)	Condensate Pump Quantity	Receiver Size (Gallons)	Motor Data			
						Voltage	Phase	Frequency	Speed



1875 Dewey Avenue Benton Harbor, Michigan 49022
 Phone 269.925.8812 Website: skidmorepump.com

MANUFACTURING AND DESIGN OF QUALITY HVAC SYSTEMS SINCE 1921

The specifications contained in this bulletin were effective at the time of publishing. We reserve the right to discontinue products at any time or to change specifications or design without incurring any obligation. For most current information, contact your Skidmore® representative.

Skidmore has been building the highest-quality condensate return pumps, boiler feed systems, vacuum systems, and accessories since 1921. From custom designs to compact solutions—our skilled representatives are armed with the knowledge and expertise to assist you in the selection, design, installation and service of your pump system. They are backed by a highly skilled team of application specialists who will provide solutions to custom engineering questions or special building capabilities and are committed to developing the most energy efficient pump to fulfill your needs. Every pump that leaves our factory has been carefully crafted and tested against the strictest standards, ensuring you receive the highest-quality product possible.

skidmorepump.com

1875 Dewey Avenue
Benton Harbor, MI
49022

+1 (269) 925-8812