

installation, operation and service instructions

VCS, VJS, VES and VNS condensate-boiler feed units

KEEP THESE INSTRUCTIONS NEAR THE PUMP FOR USE OF OPERATOR

WARNING

Before attempting examination or repairs to pump, open the disconnect switch to electric motor, to prevent accidental running of pump motor. Starting motor during examination or repair activities could damage pump and may cause personal injury. An electrical shock from contact with live wires or cords can be fatal.

Before opening conduit box of electric motor, be certain that the current to the motor is shut off. An electrical shock from contact with live motor leads can be fatal.

Let the unit cool to ambient temperature before servicing, as severe burns can result from contact.

INSTALLATION INSTRUCTIONS

Locating Pump: Install unit in a clean, dry, well-ventilated and drained location for inspection and care. The top of the pump receiver should be below the lowest return since it is best to keep the return lines dry. This unit must be placed so the condensate flows into the receiver by gravity, otherwise returns will be wet and the system will not free itself of air.

Piping: Connect returns to inlet of receiver with a gate valve in each return and with a union or flange joint next to the receiver. Provide a drain to sewer from each return. Connect discharge of pump to boiler with a union, swing check valve and a gate valve; with the swing check valve as close to the pump as is possible. If discharge pipe is longer than 50 feet, increase piping to next size larger. Piping must be of correct length to prevent any pipe strain upon the unit.

Wiring: The electrical connections between the motor, float switch and automatic starter (if furnished) are made at the factory. Connect the electric service to the float switch or automatic starter using conduit and wire sizes as required by local power companies. Provide a fused main line switch in motor circuit. CAUTION: The motor is wired and connected at the factory to operate on the voltage specified. If voltage is other than originally specified, consult motor manufacturer's instructions accompanying unit for proper wiring. Where a polyphase motor is furnished with only a float switch, IT WILL BE NECESSARY TO INSTALL A SUITABLE PHASE PROTECTOR SWITCH IN THE MOTOR CIRCUIT TO PREVENT MOTOR BURNOUTS SHOULD A SINGLE PHASE CONDITION OCCUR.

Fuses: Be sure fuses are installed and comply in size with National Electrical Code recommendations. When a fuse blows out it indicates that something is wrong either in the motor, pump, switch, fuse rating or electric service. Do not replace fuse until the cause for its blowing out has been determined. If a thermal cut-out is used, an element with a maximum tripping current rating 50% greater than motor nameplate Amps. may be selected. Condensate boiler feed pumps are only operating intermittently and therefore it is permissible.

OPERATING INSTRUCTIONS

CAUTION: New or repaired heating systems should be operated several days with the returns open to sewer until water appears clear, in order to thoroughly flush and clean the lines and prevent clogging of the pump when it is put in operation. This may take from a few days to two weeks.

This pump is equipped with a mechanical shaft seal instead of the conventional type of packing. Be sure, therefore, that pump receiver is filled with water or condensate before starting, because the mechanical seal will be damaged if run dry.

LUBRICATION: None required for pump proper. However, the vertical motor is ball bearing type with pre-sealed and lubricated bearings, and no intermediate lubrication is necessary. Required lubrication depends upon service pump is subjected to and cleanliness of location. Normal lubrication — at the start of each heating season or every 1500 hours of operation whichever comes first. DO NOT over lubricate. Use CITCO Premium Lithium #2 or equal.

Skidmore®

1875 Dewey Avenue
Benton Harbor, MI 49022
TEL - (269) 925-8812
FAX - (269) 925-7888
www.skidmorepump.com

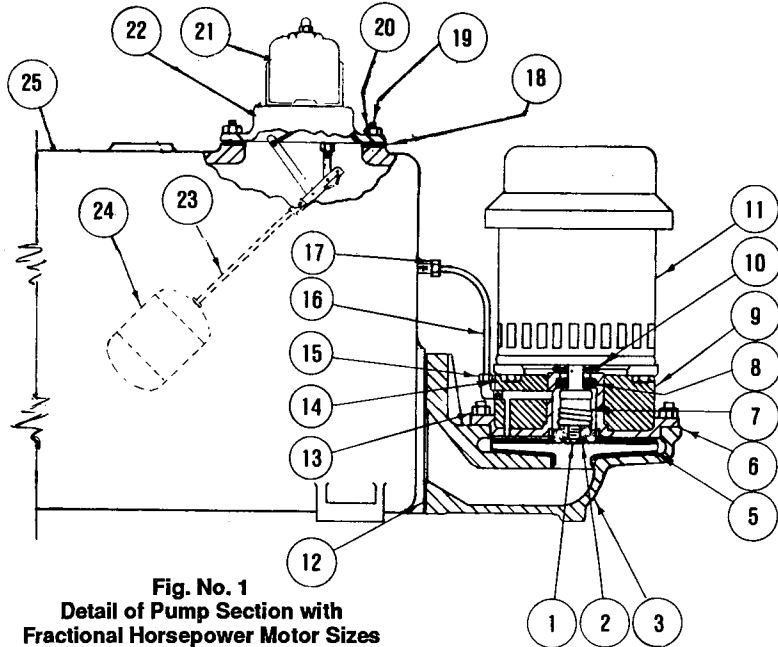

Fig. No. 1
Detail of Pump Section with
Fractional Horsepower Motor Sizes

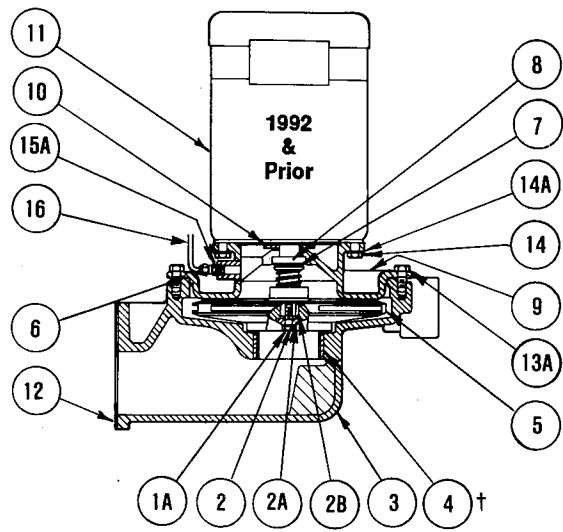

Fig. No. 2
Detail of Pump Section
VES Series

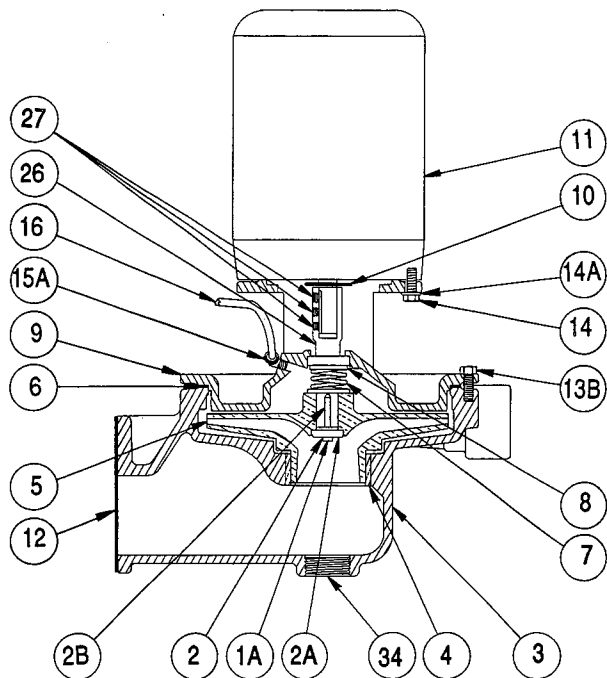

Fig. No. 3
Detail of Pump Section
VES Series beginning 1993

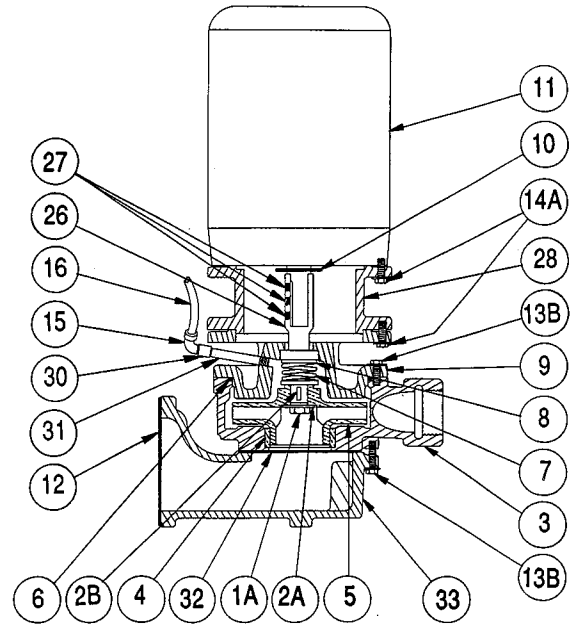

Fig. No. 4
Detail of VNS Pump

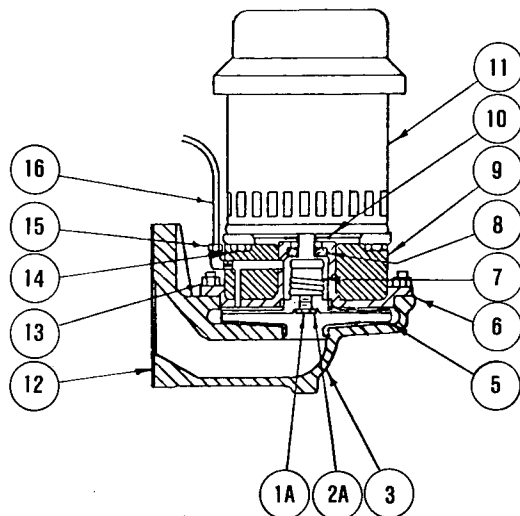

Fig. No. 5
Detail of Pump Section with
Integral Horsepower Motor Sizes

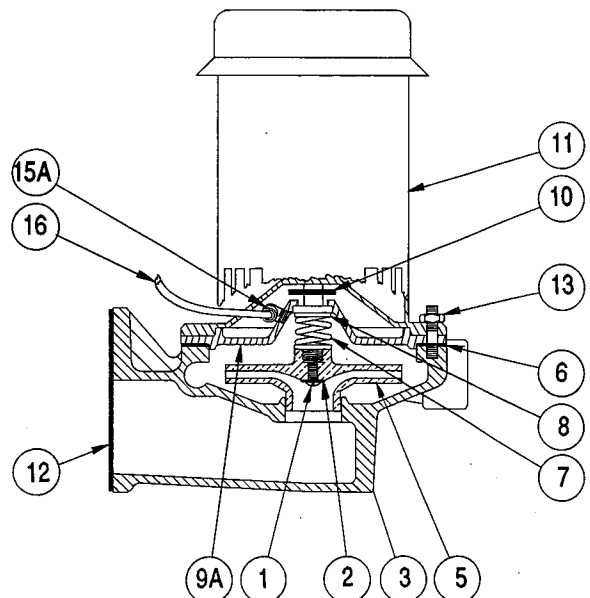

Fig. No. 6
Detail of Pump Section
VJS All Sizes

PARTS LIST

1	Impeller Lock Nut - Bronze 30	15	Vent Line Fitting - Elbow
1A	Impeller Lock Screw - Stainless Steel 10	15A	Vent Line Fitting (Seal Plate)
2	Impeller Lockwasher - Bronze	16	Pump Vent Line
2A	Impeller Retaining Collar - Bronze	17	Vent
2B	Impeller Key	18	Gasket - Float Switch
3	Pump Housing - C.I.	19*	Hex Head Cap Screw (C.I. Only) 4 Reg.
4†	Wear Ring - Bronze	20*	Hex Nut - Float Switch (Steel Only) 4 Reg.
5	Centrifugal Impeller	21	Float Switch Only
6	Gasket/O-Ring - Pump Housing to Motor Bracket	22	Float Switch and Linkage Assembly Complete with Ball and Rod
7	Rotating Seal Assembly with S.S. Sprint	23	Float Rod
8	Ceramic Seal Seat and Vibration Ring	24	Float Ball
9	Motor Bracket - C.I.	25	Receiver
9A	Seal Plate - C.I.	26	Extension Shaft
10	Water Slinger - Neoprene	27	Set Screws
11	Electric Motor	28	Stand-Off Bracket
12	Gasket - Receiver to Pump Housing	30*	Coupling - Black Pipe
13*	Hex Nut and Stud Bolt	31*	Pipe Nipple - Vent Extension
13A*	Hex Head Cap Screw	32	Gasket - Suction Adapter
13B*	Hex Head Cap Screw w/Flat Washer	33	Suction Adapter
14*	Hex Head Cap Screw	34*	Pipe Plug - Drain
14A*	Hex Head Cap Screw w/Flat Washer		

*May be purchased locally

†VES and VNS only

INSPECTION BEFORE STARTING UNIT FOR FIRST TIME

1. Check motor shaft and be sure it rotates freely. If shaft is tight, inspect pump end and motor for foreign matter clogging pump or lodging in motor.
2. Check voltage supply and be sure it is same as motor on pump, or same as wiring connections made at factory.
3. Be sure piping connections to pump have been made as per instructions and that air vent pipe from receiver is open to atmosphere.
4. Be sure that the engineering characteristics of the complete pump are identical to the capacity, discharge pressure and other requirements of the system.
5. Be sure that the float in the receiver is free to operate float switch.

Starting: Open valves in discharge and return lines, close valves in drain lines and close fused knife switch. If an automatic starter with selector switch is installed, be sure selector switch button is in "Auto" position.

INSPECTION AFTER STARTING

1. With vent pipe open to atmosphere, air and vapor can escape as fast as condensation flows into receiver. If vent is not open, or restricted, receiver will not fill.
2. Be sure pump and motor rotate in proper direction. Correct direction of rotation is CLOCKWISE when looking at top of motor. (If rotation is reversed, refer to motor instruction card and change proper leads.)
3. Check motor bearings for overheating.
4. Check float switch to see that it starts and stops motor as receiver fills and empties.
5. Check all piping connections for leaks.
6. Observe operation of unit closely for several hours after first starting and at regular intervals for several days. A new unit is frequently stiff and bearings are tight and therefore should be watched to check performance.

SERVICE AND CARE OF UNIT

1. Inspection: To insure best operation of unit, make a systematic inspection at least once a week.
2. Cleanliness: Keep the interior and exterior of motor and automatic switches free from moisture, oil and dirt. If necessary, use compressed air for blowing out dirt. Occasionally drain and flush pump receiver to remove sediment and pipe scale.
3. Motor Bearings: Prevent excessive heating and wear of ball bearings by proper lubrication, frequency depending upon service pump is subjected to and cleanliness of location. When bearings are worn and unit becomes noisy, replace worn bearings immediately so as not to injure other rotating parts.
4. Automatic Switches: Occasionally examine contacts of automatic switches and see that they make a full firm contact and break the circuit quickly. Be sure all terminal connections are tight and not corroded.
5. Mechanical Shaft Seal: Occasionally examine water slinger Part No. 10 on motor shaft and look for water leakage. Any leakage will also be visible on Part No. 9 motor bracket. Leakage indicates that the seal surfaces are worn and Parts No. 7 and 8 will need replacing. (For proper procedure in replacing these parts, refer to instructions under Disassembly of Pump.) CAUTION: NEVER OPERATE PUMP WHEN RECEIVER IS EMPTY, BECAUSE THE SEAL WILL BE DAMAGED IF RUN DRY.
6. Shutting Down: At end of heating season, open main line switch, close valves in return line and discharge piping, and drain receiver and pump. If necessary, cover electric motor and automatic switches to protect them against dirt, oil and moisture.
7. Caution: Never operate pump when receiver is empty or expose it to freezing temperature when filled with water.

REMOVING PUMP AND MOTOR UNIT

No return piping or pump discharge piping need be disturbed to remove pump and motor unit, simply proceed as follows:

- 1 - Loosen or remove vent line fitting Part No. 15 and swing tube vent line away from pump.
- 2 - Disconnect wiring and flexible conduit at motor terminal box and swing tube vent line away from pump.
- 3 - Remove nuts No. 13 or hex. head cap screw No. 13A or 13B and lift motor and pump unit from pump housing No. 3 for inspection or repair.

DISMANTLING PUMP AND MOTOR UNIT

FOR VJS PUMP UNIT proceed as follows:

- 1 - Remove drip cover from top end of motor and receiver plug from center of motor top end-bell. Note slot in top end of motor shaft (or two flats on motor shaft if it extends above end-bell.). Use either a heavy wide blade screwdriver, or open end wrench to hold motor shaft securely.
- 2 - Remove No. 1 impeller locknut with socket head wrench by turning locknut COUNTERCLOCKWISE. Also remove bronze lockwasher No. 2.
- 3 - Still holding motor shaft securely, remove No. 5 impeller by turning COUNTERCLOCKWISE. Impeller hub is threaded and screws onto threaded motor shaft.
- 4 - Remove No. 7 rotating seal assembly with spring by sliding along motor shaft. Spring seats against impeller hub.
- 5 - Remove No. 9A seal plate carefully over motor shaft.
- 6 - Water slinger No. 10 is now visible and can be removed.

FOR VCS, VES and VNS UNITS proceed as follows:

- 1 - Insert blade of screwdriver in one of the peripheral vane openings of impeller to keep shaft from turning. With another screwdriver or socket head wrench remove No. 1A impeller lock screw by turning COUNTERCLOCKWISE. Impeller lock screw may be slotted round head type or hexagon head type. Also remove lockwasher No. 2, if used.
- 2 - Remove No. 2A impeller retaining collar and with two (2) screwdriver blades 180° apart and between impeller No. 5 and bracket No. 9, pry impeller from motor shaft. The impeller hub has a straight bore and motor shaft is straight with a key and keyway. Remove key No. 2B in motor shaft.
- 3 - Remove No. 7 rotating seal assembly with spring by sliding along motor shaft. Spring seats against impeller hub.
- 4 - Remove No. 14 hex. cap screws, holding bracket to motor, and remove bracket No. 9 from motor.
- 5 - Water slinger No. 10 is now visible and can be removed.

REPLACING MECHANICAL SHAFT SEAL AND REASSEMBLING PUMP

- 1 - Pump and motor unit must be completely dismantled as indicated above.
- 2 - Remove No. 8 ceramic stationary seal seat and rubber vibration ring from motor bracket No. 9 or seal plate 9A.
- 3 - Be sure counter-bore in bracket No. 9 or 9A is perfectly clean before inserting new ceramic seat and ring.
- 4 - Use a light oil on the entire diameter of vibration ring and press it together with the ceramic seat into the machined bore of bracket No. 9. Press as far as it will go and be sure it is in proper position with seat surface at a perfect 90° angle with respect to motor shaft. Use caution so as NOT to SCRATCH or MAR lapped surfaces of ceramic seat.
- 5 - Slide No. 9 motor bracket over motor shaft and replace screws No. 14. (Seal plate No. 9A for VJS pumps - No. 14 HHCS N/A).
- 6 - Use light oil on lower end of motor shaft and slip rotating seal assembly No. 7 onto motor shaft as far as it will go. CAUTION: Be careful not to SCRATCH or MAR lapped surface of carbon ring.
- 7 - Insert seal spring and be sure it seats properly against shaft seal.
- 8 - VJS PUMP UNIT: Hold top end of motor shaft with screwdriver or open end wrench and screw impeller No. 5 CLOCKWISE onto motor shaft until it is tight. The seal spring will center itself on hub of impeller and it will be properly compressed for seal compression.
- 9 - Replace lockwasher No. 2 and locknut No. 1 and turn locknut CLOCKWISE until tight.
- 8A - VCS, VES and VNS PUMP UNITS: Replace impeller key in motor shaft and replace impeller on shaft. With impeller in proper place, the inside hub will be almost flush with end of motor shaft and seal spring will have proper compression.
- 9A - Insert screwdriver blade in one of the impeller peripheral openings to keep it from turning, and replace No. 2A retaining collar, lockwasher No. 2 (if used) and No. 1A locking screw. Tighten impeller locking screw by turning CLOCKWISE.
- 10 - Replace gasket/O-ring No. 6 and set pump and motor unit onto pump housing No. 3 and replace stud nuts No. 13 or hex. head screws No. 13A or 13B and tighten securely.
- 11 - Replace tube vent line No. 16 and tighten fittings No. 15.
- 12 - Reconnect wiring and flexible conduit at motor terminal box and unit is now ready for operation. (Check rotation.)
- 13 - CAUTION: NEVER RUN PUMP WITH RECEIVER EMPTY, BECAUSE BOTH ELEMENTS OF MECHANICAL SHAFT SEAL WILL BE DAMAGED.

Overflows and Vents

Proper installation of overflow and vent piping is critical to the success of your installation. The tank you have purchased is not a pressure vessel and properly locating the overflow and vent piping will help prevent damage to the tank.

The purpose of the **overflow** is to provide a path for the tank contents to escape the tank in the event of flooding caused by mechanical or electrical failure. An overflow should extend no higher than one foot above the top of the tank, because each additional foot of height in the overflow adds about 1/2 psi to the pressure in the vessel. Overflows typically are directed into floor drains.

The purpose of the **vent** is to maintain atmospheric pressure on top of the liquid in the tank (that is, to prevent pressurization by the process). There is no limit to the height of the vent, since it is only carrying air at low velocity. Tall vents should be supported from above to ensure stability and to reduce weight load on the tank.

Some tanks have separate vent and overflow ports, while others have a single port that must serve both purposes. See the figure below for the proper method for plumbing vent and overflow to a single port. **Never reduce pipe size on vent or overflow lines.**

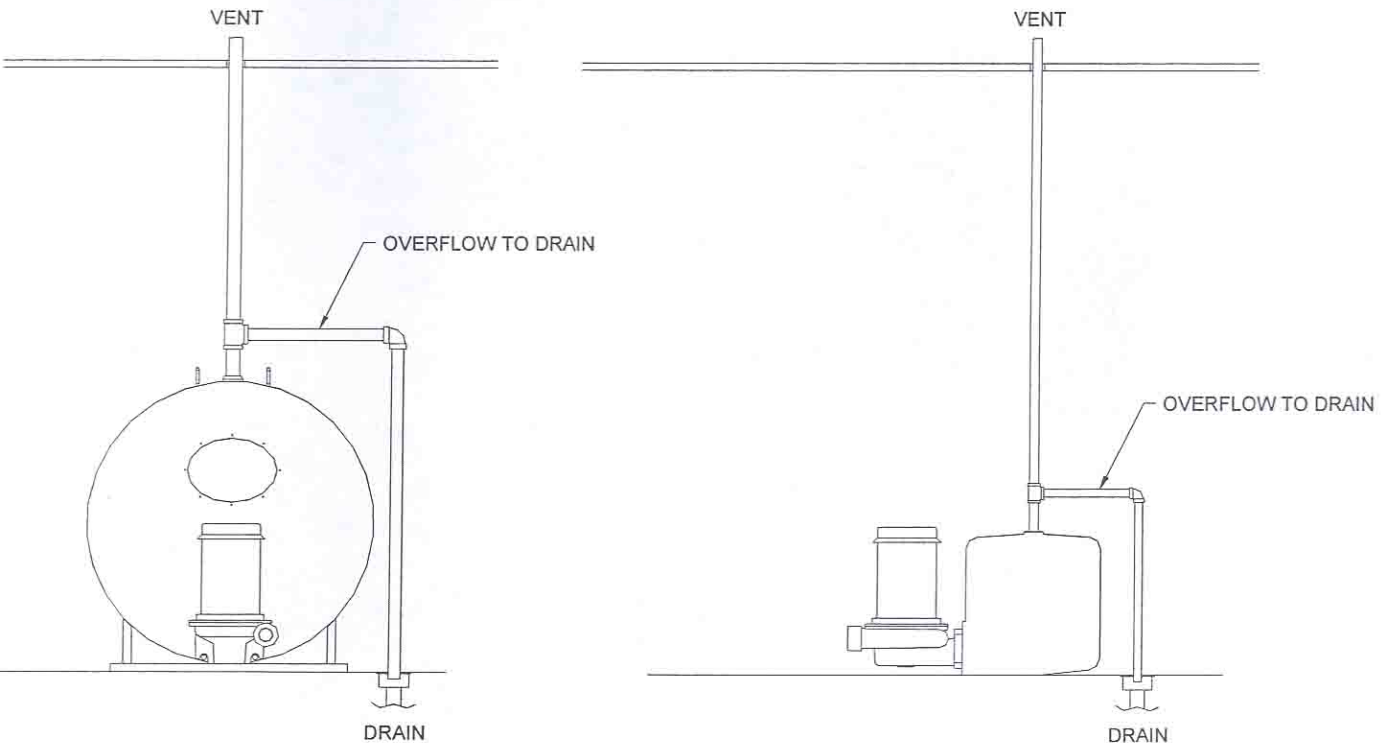

Return Line Strainer

Use of a strainer in the return to the receiver is recommended. The strainer collects solids of a certain size, and removes them from the condensate. Strainers typically have access covers that allow removal of the strainer basket or screen for cleaning. The proper location of the strainer is in the condensate return line near its entry point to the tank.