

# SUBMITTAL DATA SHEET

X-POT-COMPACT MODEL# 58760

EFFECTIVE DATE: JANUARY, 2017

Job Name		Contractor	
Job Location		Approval	
Engineer		Contractor P.O. No.	
Approval		Representative	

## X-POT COMPACT® SPECIFICATION

- All stainless steel construction including all 1/2" Valves and 1/2" fittings
- AAV (automatic air vent) = BRASS
- Dosing Capacity: 1.18 gal
- Factory Test Pressure: 225 PSI
- Max Working Pressure: 150 PSI
- Flow Rate: Up to 6.3 Gal/m (clean filters)
- Max System Volume: 9,130 Gallons
- Temp Range: 32 to 200 F
- Weight: Empty = 35lbs, Full = 45lbs, Shipping = 50lbs
- 1SS magnet grate containing 4 rare earth magnets
- 1SS baffle plate
- Compatible with 100, 50, 20, 5 & 0.5µ cartridge filters
- Wall Mounted

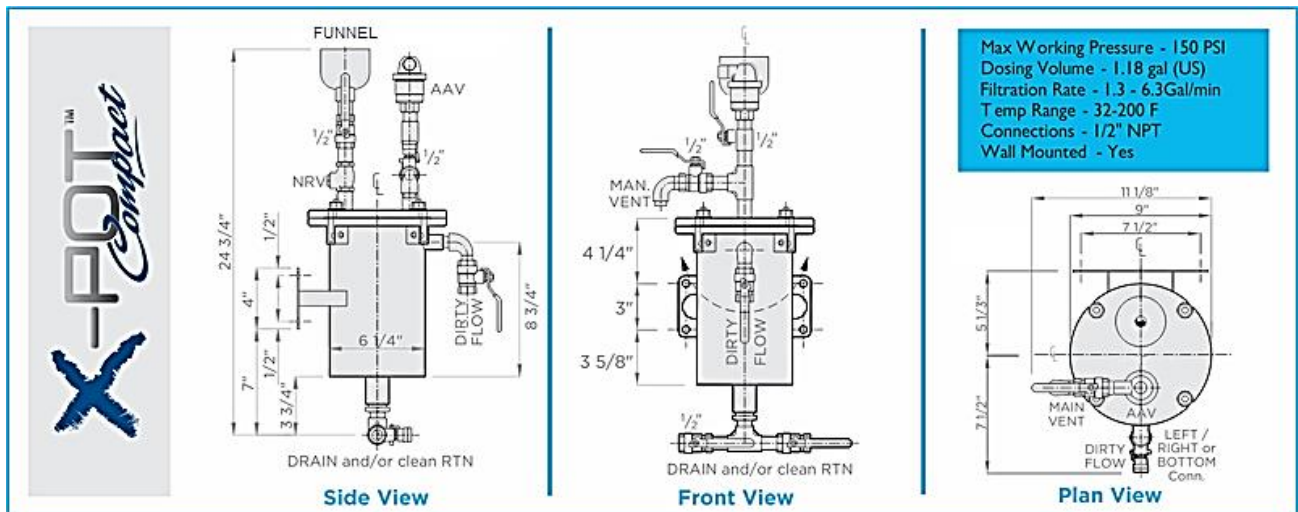

1875 DEWEY AVE BENTON HARBOR, MICHIGAN 49022  
 WWW.SKIDMOREPUMP.COM